

SCHEDULE CLAMP

Part Number	Size	A	B	Thread
13MHHV-1	1"	2.12 +/- .010	.750	5/16-18
13MHHV-1.5	1 1/2"	2.65 +/- .010	.750	5/16-18
13MHHV-2	2"	3.19 +/- .010	.750	5/16-18
13MHHV-2.5	2 1/2"	3.72 +/- .010	.750	5/16-18
13MHHV-3	3"	4.26 +/- .010	.750	5/16-18
13MHHV-4	4"	5.26 +/- .010	.750	5/16-18
13MHHV-6	6"	7.32 +/- .020	1.000	3/8-16
13MHHV-8	8"	9.32 +/- .020	1.000	3/8-16
13MHHV-10	10"	11.45 +/- .020	1.000	3/8-16
13MHHV-12	12"	13.31 +/- .020	1.250	3/8-16

*FOR GENERAL INFORMATION PURPOSES ONLY
ACTUAL APPEARANCE MAY VARY.

WINGNUT WITH HOLE
(DESIGN AS SHOWN)
(DIMENSIONS MAY VARY)

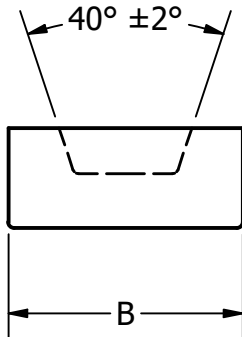
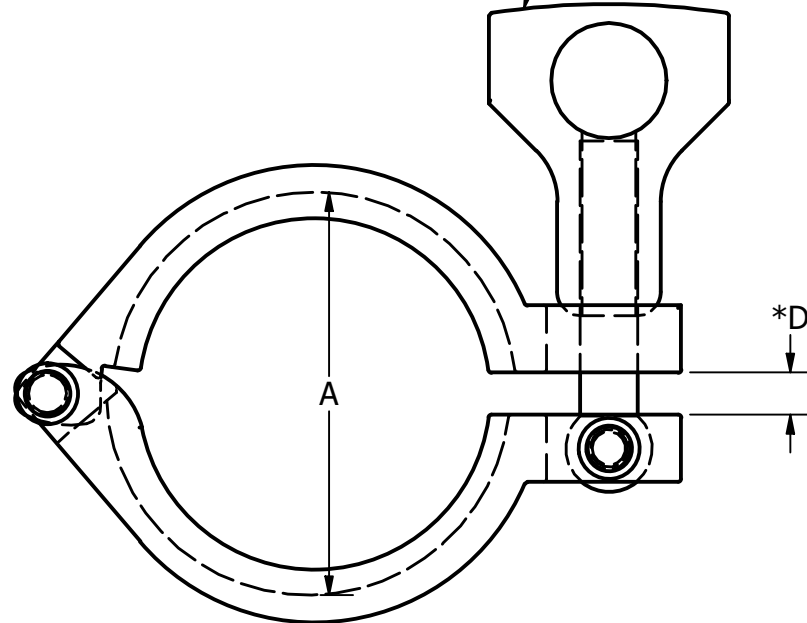

ALL DIMENSIONS IN INCHES

* - ALL DIMENSIONS CHECKED FROM THIS
DIMENSION

TOLERANCES REFER TO STEEL & O'BRIEN DOCUMENT # QS121	Steel & O'Brien Mfg. Inc.	
	TITLE HEAVY DUTY SCHEDULE CLAMP	
	DWG NO: 13MHHV	REV
	SCALE: 1 : 1	SHEET 1 OF 1